



TOYOTA

RS2000 SERIES

SERVICE MANUAL

AIN

Introduction

Notice on the Service Manual

1. This Service Manual for the RS2000 sewing machines is written to assist users in properly diagnosing and correcting problems with the machine. Please read through this Service Manual carefully and utilize it as a reliable guide for daily service activities.
2. This Manual is composed of the following sections.
 1. Specification
 2. Troubleshooting
 3. Adjustment of respective parts
 4. Removal and reassembling of main components

When referring to this Service Manual for repair or others, start to read the "Troubleshooting" for correct diagnosis and then proceed to the "Adjustment of respective sections" or "Removal and reassembling of main components".

Important safety instruction

Following describes the safety instructions to prevent possible risks, damages or losses resulting from improper handling in the repair, inspection or operation of the RS2000. Please read these instructions carefully and observe them faithfully.

Meaning of warning symbols (⚠ WARNING and ⚠ CAUTION):

WARNING

Mortal or serious injury could result from improper handling.

CAUTION

Physical injury or material loss could result from improper handling.

Precautions during inspection:

WARNING

1. Make sure to turn the power supply off before starting the repair work.
 - ♦There is risk of electric shock.
2. After removing parts for repair, or others, make sure to secure the electrical safety for the handling of the sewing machine in accordance with local laws and regulations concerning electrical operations.
 - ♦There is risk of electric shock.

CAUTION

1. When leaving from the sewing machine, turn off the power supply switch or disconnect the power cable plug from the power outlet.
 - ♦There is risk of injury.

IMPORTANT

1. When replacing parts, use only the genuine parts supplied by us in order to assure the performance of the sewing machine.

CONTENTS

1.Specifications.....	4
2.Troubleshooting	5
1.Improper tightness of stitches.....	5
2.Skip stitch	7
3.Thread breakage	10
4.Broken or bent needle	13
5.Improper fabric feed	16
6.Disrupted pattern	18
7.Improper buttonhole sewing	21
8.Improper lower thread winding length	22
9.Improper upper threading	23
3.Adjustment of respective parts	24
1.Needle bar position.....	24
2.Timing between needle and hook.....	26
3.Clearance between needle and upper plate spring	28
4.Stitch width	29
5.Needle location.....	30
6.Needle sideways movement.....	32
7.Thread tension.....	33
8.Feed dog position	34
9.Lower thread winding length.....	36
10.Presser foot height	37
11.Needle threader	38
12.Buttonhole sewing	39
13.Feeding amount.....	41
14.Clearance between shuttle driver and shuttle hook.....	42
15.Belt tension.....	43
4.Removal and reassembling of main components.....	45
1.External panels, etc.	45

1.Specifications

RS2000

Item\Type	SD	2D	3D
Type of stitch	Straight lock stitch/zigzag sewing		
Needle to be used	HA x 1, # 11 to 16 (Standard : # 14)		
Hook type	Vertical half-turn rotary hook		
Take-up lever type	Link take-up lever		
Stitch length	Fixed for each pattern	Adjust dial type: Max. 5 mm	
Stitch width	Fixed for each pattern		Adjust lever type: Max. 5 mm
Straight stitch needle standard position	Center, Left		
Type of pattern	18 types		20 types
Buttonhole type	4-step buttonhole		1-step buttonhole
Sewing speed	Max.: 800 rpm		
Pattern selection	Dial type, endless bi-directional		
Reverse stitching	Lever type		
Presser bar lifter	2-step select lever type		
Under thread winder	Needle stop by selector knob		
Accessory	Stored under the extension table		

RS2000 Series

* Pattern selection dial may be positioned on the right side face.

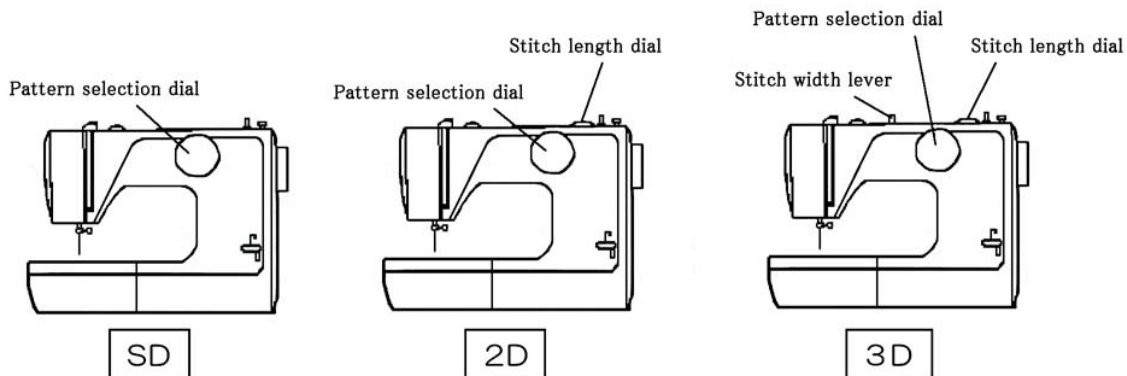

2.Troubleshooting

1.Improper tightness of stitches

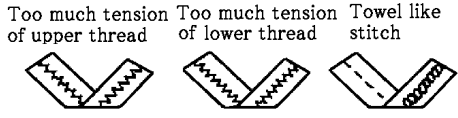
<p>[Example of phenomenon]</p> <p>Too much tension of upper thread Too much tension of lower thread Towel like stitch</p> 	<p>[Check item before adjustment]</p> <ul style="list-style-type: none"> ◆Are upper and lower threads threaded properly? ◆Is the combination of needle and thread adequate for the fabric?
---	--

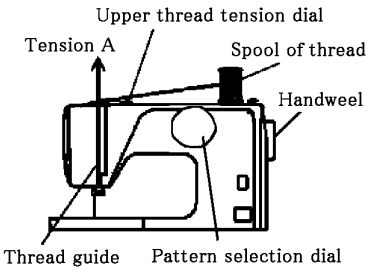
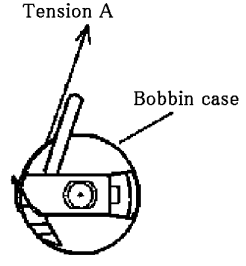
Step	Item	Diagnosing Method	Standard	Reference Page
1. Upper thread tension dial	Upper thread tension	 <p><Condition> Upper thread tension dial: "5" Thread: Cotton yarn # 60</p> <p><Diagnosis></p> <ul style="list-style-type: none"> ◆Pass the upper thread from the spool of thread to the thread guide, pull the thread vertically and measure the tension (A) when the value has stabilized. (Using a measuring instrument) 	A = 0.85 to 1.15 N	[Adjustment] page.33
2. Bobbin case	Lower thread tension	 <p><Condition> Thread: Cotton yarn # 60</p> <p><Diagnosis></p> <ul style="list-style-type: none"> ◆After setting the bobbin in the bobbin case, pull out the lower thread through the lower thread guide. Measure the tension (A) when the value has stabilized. (Using a measuring instrument.) 	A = 0.3 to 0.4 N	[Adjustment] page.33

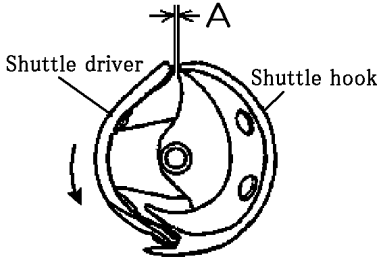
Step	Item	Diagnosing Method	Standard	Reference Page
3. Hook	Clearance between shuttle driver and shuttle hook	 <p><Diagnosis></p> <ul style="list-style-type: none"> ◆ Remove the extension table, and open the shuttle cover. ◆ Remove the bobbin case from the hook. ◆ When the shuttle driver is turned to left by rotating the handweel, measure the clearance (A) between the shuttle driver and the shuttle hook. 	A = 0.3 to 0.6 mm	[Adjustment] page.42

2.Skip stitch

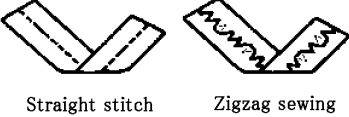
<p>[Example of phenomenon]</p> <p>Uneven stitch</p>  <p>Straight stitch Zigzag sewing</p>	<p>[Check item before adjustment]</p> <ul style="list-style-type: none"> ♦Is home-use sewing machine needle (HA x 1)used? ♦Is the needle installed correctly? ♦Is the needle bent? ♦Is the combination of needle and thread adequate for the fabric? ♦Is the upper thread threaded properly?
---	---

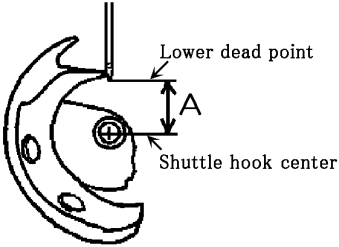
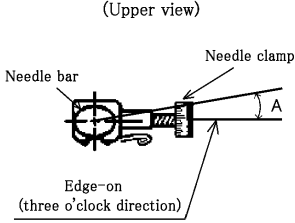
Step	Item	Diagnosing Method	Standard	Reference Page
1. Needle and hook	Needle bar height	 <p><Condition> Needle: # 14</p> <p><Diagnosis></p> <ul style="list-style-type: none"> ♦Remove the extension table, and open the shuttle cover. ♦When the needle bar is brought to the lower dead point by rotating the handwheel, measure the clearance (A) between the needle point and the shuttle hook center. 	A = 11.2 ± 0.2 mm	[Adjustment] page.24
	Needle bar direction	<p>(Upper view)</p>  <p><Diagnosis></p> <ul style="list-style-type: none"> ♦Remove the face cover. ♦Check the needle clamp position. ♦When seeing from the top, measure the angle (A) in the figure. 	Needle clamp position: Just beside when seeing from the top (right side seeing from the front) A= 0° to 1.5°	[Remove] page.45 [Adjustment] page.24

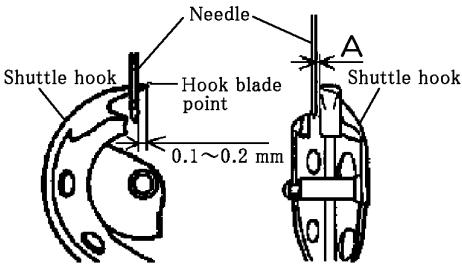
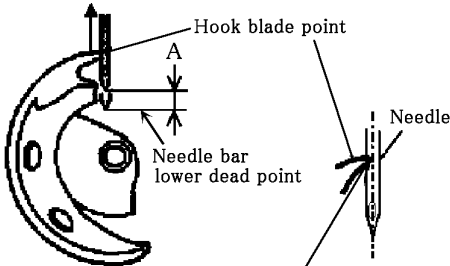
Step	Item	Diagnosing Method	Standard	Reference Page
1. Needle and hook	Clearance between needle and hook	 <p><Condition> <SD> Pattern selection dial: "6" <2D> Pattern selection dial: "4" <3D> Pattern selection dial: "3" Stitch width lever: "0" <Diagnosis> • Turn the handwheel beyond the lower dead point of needle bar. When the hook blade point has protruded by 0.1 to 0.2 mm from the side face of needle, measure the clearance (A) between the needle and the hook.</p>	A = 0.03 to 0.08 mm	[Adjustment] page.26
	Amount of needle elevation	 <p>Blade point aligns with needle center.</p> <p><Condition> <SD> Pattern selection dial: "5" <2D> Pattern selection dial: "3" <3D> Pattern selection dial: "4" <Diagnosis> • Remove the extension table, and open the shuttle cover. • When the hook blade point is aligned with the needle center by rotating the handwheel, measure the travel distance (A) of needle bar, regarding the lower dead point of needle bar as 0.</p>	A = 1.85 ± 0.15 mm	[Adjustment] page.26

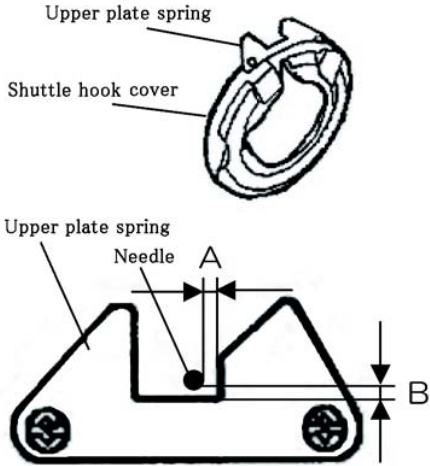
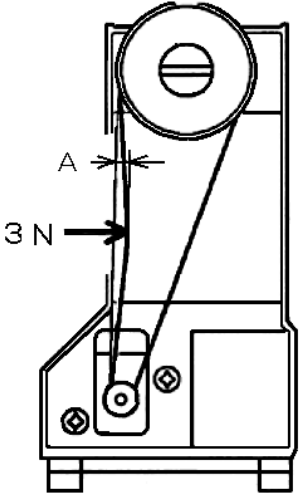
Step	Item	Diagnosing Method	Standard	Reference Page
2. Needle and upper plate spring	Clearance between needle and upper plate spring	 <p><Condition> <SD> Pattern selection dial: "11" <2D> Pattern selection dial: "7" <3D> Pattern selection dial: "3" Stitch width lever: "5"</p> <p><Diagnosis> ♦When the needle bar is brought to the lower dead point at the right side by rotating the handwheel, measure the clearance (A, B) between the needle and the upper plate spring.</p>	A = 0.5 to 1.2 mm B = 0.5 to 1.0 mm	[Adjustment] page.28
3. Motor belt	Motor belt tension	 <p><Diagnosis> ♦Remove external panels and others. ♦When pressing the center of motor belt with a force of 3N, measure the depth of flexure (A) on the belt.</p>	A = 7.0 to 9.0 mm	[Remove] page.45 [Adjustment] page.43

3.Thread breakage

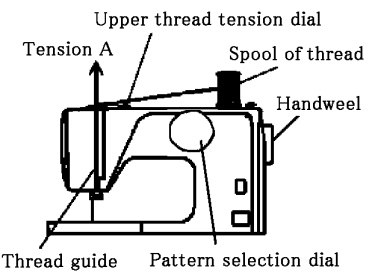
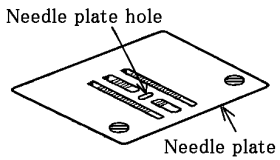
Step	Item	Diagnosing Method	Standard	Reference Page
<p>[Example of phenomenon]</p> 		<p>[Check item before adjustment]</p> <ul style="list-style-type: none"> ◆Is home-use sewing machine needle (HA x 1)used? ◆Is the needle installed correctly? ◆Is the needle bent or deformed? ◆Is the combination of needle and thread adequate for the fabric? ◆Is the upper thread tension set correctly? ◆Are upper and lower threads threaded properly? 		
<p>1. Upper thread tension dial</p>	<p>Upper thread tension</p>	 <p><Condition> Upper thread tension dial: "5" Thread: Cotton yarn # 60</p> <p><Diagnosis></p> <ul style="list-style-type: none"> ◆Pass the upper thread from the spool of thread to the thread guide, pull the thread vertically and measure the tension (A) when the value has stabilized. (Using a measuring instrument) 	<p>A = 0.85 to 1.15 N</p>	<p>[Adjustment] page.33</p>
<p>2. Needle plate</p>	<p>Flaw on needle plate</p>	 <p><Diagnosis></p> <ul style="list-style-type: none"> ◆Check the needle plate by touching around the needle plate hole. 	<p>Flaw not allowed.</p>	<p>Repair with sand paper (#800).</p>

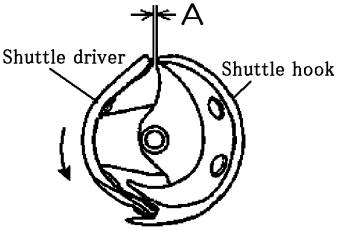
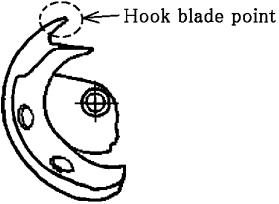
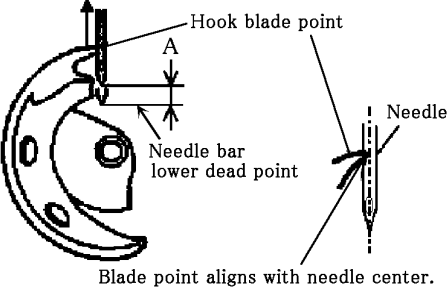
Step	Item	Diagnosing Method	Standard	Reference Page
3. Hook	Clearance between shuttle driver and shuttle hook	 <p><Diagnosis></p> <ul style="list-style-type: none"> ◆Remove the extension table, and open the shuttle cover. ◆Remove the bobbin case from the hook. ◆When the shuttle driver is turned to left by rotating the handweel, measure the clearance (A) between the shuttle driver and the shuttle hook. 	A = 0.3 to 0.6 mm	[Adjustment] page.42
	Flaw on hook blade point	 <p><Diagnosis></p> <ul style="list-style-type: none"> ◆Check the hook blade point by touching the hook blade point with finger. 	Flaw not allowed.	Repair with sand paper (#800).
4. Needle and hook	Amount of needle elevation	 <p>Blade point aligns with needle center.</p> <p><Condition></p> <p><SD> Pattern selection dial: "5"</p> <p><2D> Pattern selection dial: "3"</p> <p><3D> Pattern selection dial: "4"</p> <p><Diagnosis></p> <ul style="list-style-type: none"> ◆Remove the extension table, and open the shuttle cover. ◆When the hook blade point is aligned with the needle center by rotating the handweel, measure the travel distance (A) of needle bar, regarding the lower dead point of needle bar as 0. 	A = 1.85 ± 0.15 mm	[Adjustment] page.26

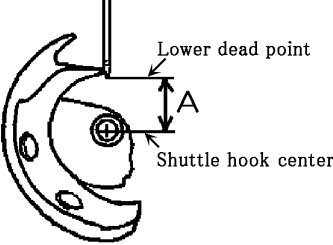
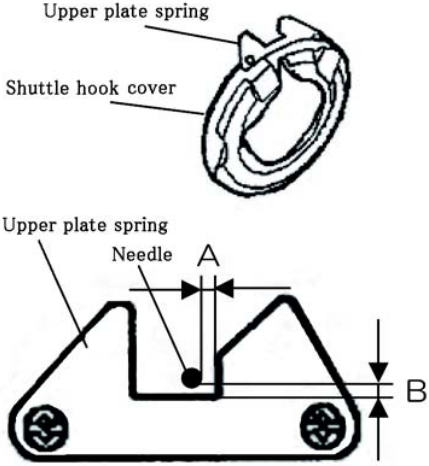
Step	Item	Diagnosing Method	Standard	Reference Page
4. Needle and hook	Needle bar height	 <p><Condition> Needle: # 14</p> <p><Diagnosis></p> <ul style="list-style-type: none"> ◆ Remove the extension table, and open the shuttle cover. ◆ When the needle bar is brought to the lower dead point by rotating the handwheel, measure the clearance (A) between the needle point and the shuttle hook center. 	A = 11.2 ± 0.2 mm	[Adjustment] page.24
5. Needle and upper plate spring	Clearance between needle and upper plate spring	 <p><Condition> <SD> Pattern selection dial: "11" <2D> Pattern selection dial: "7" <3D> Pattern selection dial: "3" Stitch width lever: "5"</p> <p><Diagnosis></p> <ul style="list-style-type: none"> ◆ When the needle bar is brought to the lower dead point at the right side by rotating the handwheel, measure the clearance (A, B) between the needle and the upper plate spring. 	A = 0.5 to 1.2 mm B = 0.5 to 1.0 mm	[Adjustment] page.28

4. Broken or bent needle

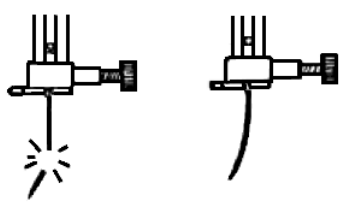
<p>[Example of phenomenon]</p> 	<p>[Check item before adjustment]</p> <ul style="list-style-type: none"> ◆Is home-use sewing machine needle (HA x 1) used? ◆Is the needle installed correctly? ◆Is the upper thread threaded properly? ◆Is a proper presser foot used? ◆Is the upper thread tension too strong?
--	--

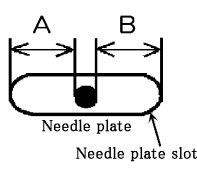
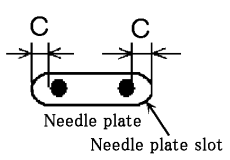
Step	Item	Diagnosing Method	Standard	Reference Page
1. Needle and needle plate	Needle dropping points (At straight stitching)	 <p><Condition> <SD> Pattern selection dial: "6" <2D> Pattern selection dial: "4" <3D> Pattern selection dial: "3" Stitch width lever: "0" <Diagnosis> ◆Rotate the handwheel, bring down the needle lower than the surface of needle plate. ◆Measure the relative position (A, B) between the needle and the slot.</p>	A = B	[Adjustment] page.30
	Needle dropping points (At maximum zigzag stitching)	 <p><Condition> <SD> Pattern selection dial: "11" <2D> Pattern selection dial: "7" <3D> Pattern selection dial: "3" Stitch width lever: "5" <Diagnosis> ◆Rotate the handwheel, bring down the needle lower than the surface of needle plate. ◆Measure the relative position (C) between the needle and the slot.</p>	C = 0.7 ± 0.3 mm	[Adjustment] page.30

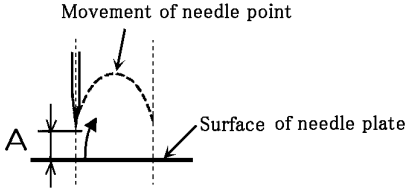
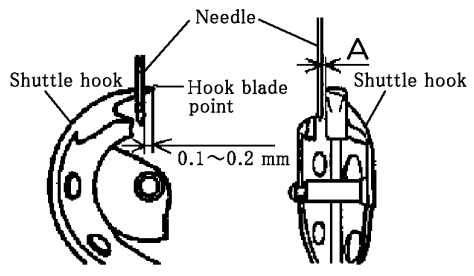
Step	Item	Diagnosing Method	Standard	Reference Page
1. Needle and needle plate	Needle sideways movement	 <p><Condition> <SD> Pattern selection dial: "11" <2D> Pattern selection dial: "7" <3D> Pattern selection dial: "3" Stitch width lever: "5"</p> <p><Diagnosis> ♦When the needle travels from left to right, measure the distance (A) from the surface of needle plate to the needle point.</p>	<SD, 2D> A = 5 to 7 mm <3D> A = 3 to 5 mm	[Adjustment] page.32
2. Needle and hook	Clearance between needle and hook	 <p><Condition> <SD> Pattern selection dial: "6" <2D> Pattern selection dial: "4" <3D> Pattern selection dial: "3" Stitch width lever: "0"</p> <p><Diagnosis> ♦Turn the handwheel beyond the lower dead point of needle bar. When the hook blade point has protruded by 0.1 to 0.2 mm from the side face of needle, measure the clearance (A) between the needle and the hook.</p>	A = 0.03 to 0.08 mm	[Adjustment] page.26

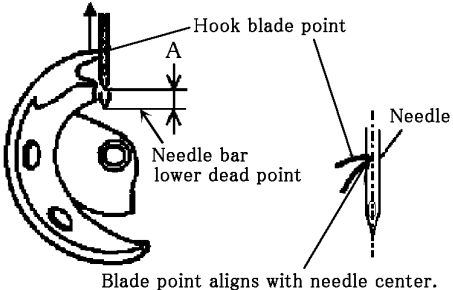
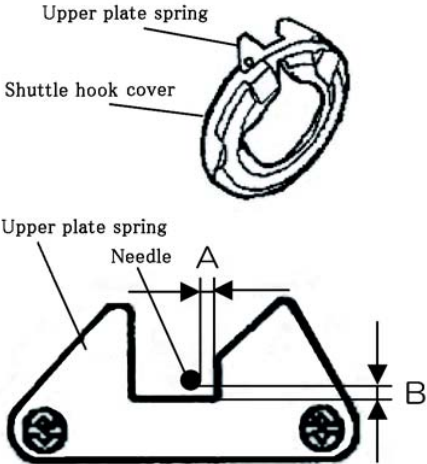
Step	Item	Diagnosing Method	Standard	Reference Page
2. Needle and hook	Amount of needle elevation	 <p>Blade point aligns with needle center.</p> <p><Condition> <SD> Pattern selection dial: "5" <2D> Pattern selection dial: "3" <3D> Pattern selection dial: "4"</p> <p><Diagnosis> ♦Remove the extension table, and open the shuttle cover. ♦When the hook blade point is aligned with the needle center by rotating the handweel, measure the travel distance (A) of needle bar, regarding the lower dead point of needle bar as 0.</p>	A = 1.85 ± 0.15 mm	[Adjustment] page.26
3. Needle and upper plate spring	Clearance between needle and upper plate spring	 <p><Condition> <SD> Pattern selection dial: "11" <2D> Pattern selection dial: "7" <3D> Pattern selection dial: "3" Stitch width lever: "5"</p> <p><Diagnosis> ♦When the needle bar is brought to the lower dead point at the right side by rotating the handweel, measure the clearance (A, B) between the needle and the upper plate spring.</p>	A = 0.5 to 1.2 mm B = 0.5 to 1.0 mm	[Adjustment] page.28

5.Improper fabric feed

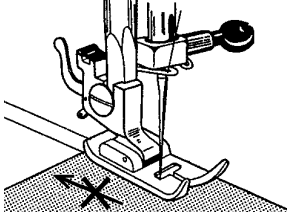
<p>[Example of phenomenon]</p> 	<p>[Check item before adjustment]</p> <ul style="list-style-type: none"> ◆Is the stitch length dial adjusted properly? ◆Is the presser foot pressure appropriate? ◆Is the presser foot lowered firmly? ◆Check if dirt is accumulated on the feed dog. ◆Is the feed dog lifted?
--	---

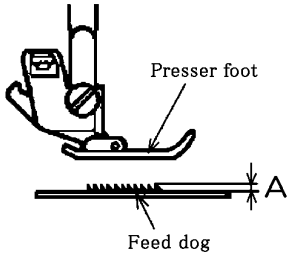
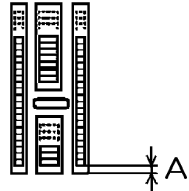
Step	Item	Diagnosing Method	Standard	Reference Page
1. Feed dog	Feed dog height	 <p><Diagnosis></p> <ul style="list-style-type: none"> ◆Bring up the presser foot and attach the needle on the needle bar. (Clarification of needle bar position) ◆When the feed dog is brought to the highest position (= upper dead point of needle bar) by rotating the handweel, measure the distance (A) between the surface of needle plate and the upper limit of feed dog. 	A = 1.15 ± 0.1 mm	[Adjustment] page.34
	Fore and aft position of feed dog	 <p><Condition> <SD> Pattern selection dial: "8" <2D, 3D> Stitch length dial: "5"</p> <p><Diagnosis></p> <ul style="list-style-type: none"> ◆Remove the presser foot. ◆When the feed dog is brought to the highest position (= upper dead point of needle bar) by rotating the handweel, measure the fore and aft position (A) of feed dog. 	A = 1.0 ± 0.5 mm	[Adjustment] page.34

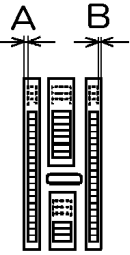
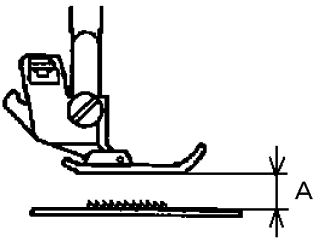
Step	Item	Diagnosing Method	Standard	Reference Page
1. Feed dog	Sideways position of feed dog	 <p><Diagnosis></p> <ul style="list-style-type: none"> ◆Remove the presser foot. ◆When the feed dog is brought to the highest position (= upper dead point of needle bar) by rotating the handwheel, measure the sideways position (A, B) of feed dog. 	A = B	[Adjustment] page.34
2. Presser foot	Presser foot height	 <p><Diagnosis></p> <ul style="list-style-type: none"> ◆Set the presser foot. ◆Lift the presser foot. ◆Measure the clearance (A) between the presser foot and the surface of needle plate. 	A = 5 to 6 mm	[Adjustment] page.37

6. Disrupted pattern

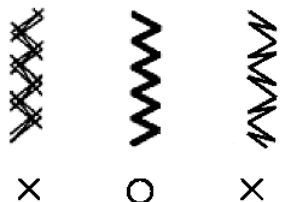
[Example of phenomenon]	[Check item before adjustment]
	<ul style="list-style-type: none"> ◆ Is the stitch length dial adjusted the properly? ◆ Is the presser foot pressure appropriate? ◆ Is the feed dog lifted? ◆ Is the stitch width lever positioned correctly?

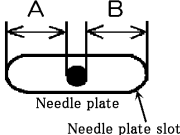
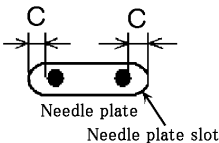
Step	Item	Diagnosing Method	Standard	Reference Page
1. Needle and needle plate	Needle dropping points (At straight stitching)	 <p><Condition> <SD> Pattern selection dial: "6" <2D> Pattern selection dial: "4" <3D> Pattern selection dial: "3" Stitch width lever: "0" <Diagnosis> ◆ Rotate the handwheel, bring down the needle lower than the surface of needle plate. ◆ Measure the relative position (A, B) between the needle and the slot.</p>	A = B	[Adjustment] page.30
	Needle dropping points (At maximum zigzag stitching)	 <p><Condition> <SD> Pattern selection dial: "11" <2D> Pattern selection dial: "7" <3D> Pattern selection dial: "3" Stitch width lever: "5" <Diagnosis> ◆ Rotate the handwheel, bring down the needle lower than the surface of needle plate. ◆ Measure the relative position (C) between the needle and the slot.</p>	C = 0.7 ± 0.3 mm	[Adjustment] page.30

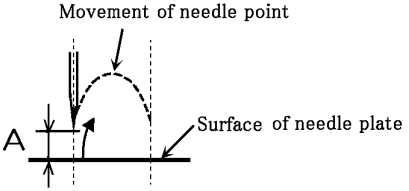
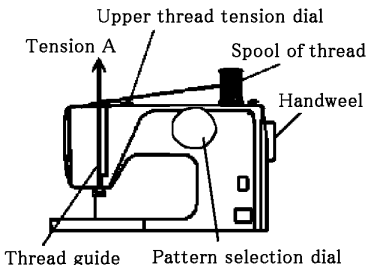
Step	Item	Diagnosing Method	Standard	Reference Page
1. Needle and needle plate	Needle sideways movement	 <p><Condition> <SD> Pattern selection dial: "11" <2D> Pattern selection dial: "7" <3D> Pattern selection dial: "3" Stitch width lever: "5"</p> <p><Diagnosis> ♦When the needle travels from left to right, measure the distance (A) from the surface of needle plate to the needle point.</p>	<SD, 2D> A = 5 to 7 mm <3D> A = 3 to 5 mm	[Adjustment] page.32
2. Upper thread tension dial	Upper thread tension	 <p><Condition> Upper thread tension dial: "5" Thread: Cotton yarn # 60</p> <p><Diagnosis> ♦Pass the upper thread from the spool of thread to the thread guide, pull the thread vertically and measure the tension (A) when the value has stabilized. (Using a measuring instrument)</p>	A = 0.85 to 1.15 N	[Adjustment] page.33

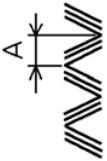
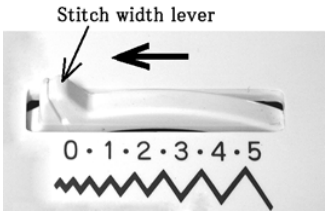
Step	Item	Diagnosing Method	Standard	Reference Page
3. State of pattern (Exclude SDU type)	Pattern stitch feeding amount	 <p><Condition> <SD, 2D> Pattern selection dial: "16" <3D> Pattern selection dial: "17" Stitch width lever: "5"</p> <p><Diagnosis> ♦Measure the maximum feeding amount (A) during pattern stitch.</p>	<p>$A = 2.8 \pm 0.3$ mm</p> <p>Pattern shall not be opened or overlapped.</p>	<p>[Adjustment] page.41</p>
4. Stitch width lever (3D only)	Lever position	 <p><Condition> Pattern selection dial: "4"</p> <p><Diagnosis> ♦Move the stitch width lever to left till the lever is stopped. ♦Check the state of stitch after sewing a fabric.</p>	<p>Stitches must be straight.</p>	<p>[Adjustment] page.29</p>

7.Improper buttonhole sewing

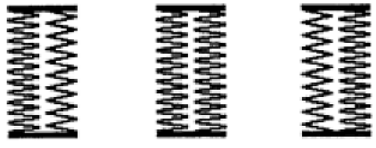
[Example of phenomenon]	[Check item before adjustment]
 <p style="text-align: center;">X O X</p>	<ul style="list-style-type: none"> ◆Is genuine buttonhole foot used? ◆Is the stitch length dial set at "0.25 to 1.0"? (2D, 3D only) ◆Is the stitch width lever set at "3 to 5"? (3D only) ◆Is the presser foot pressure appropriate? ◆Is the feed dog lifted? ◆Can it be adjusted by using the buttonhole stitch adjuster?

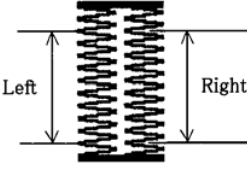
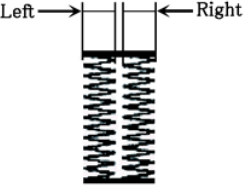
Step	Item	Diagnosing Method	Standard	Reference Page
1. State of buttonhole	Difference between right and left stitches	 <p><Condition> Presser foot: Buttonhole foot Buttonhole stitch adjuster : Center <SD> Pattern selection dial: "1" to "4" <2D> Pattern selection dial: "11" to "14" <3D> Pattern selection dial: "8" <Diagnosis> ◆When about 50 stitches have been stitched each at right and left sides of buttonhole, measure the difference of stitches at right and left.</p>	Left: 35 stitches, standard Right: 30 to 41 stitches Feeding amounts are nearly the same at right and left.	[Adjustment] page.39
	Differential width at right and left (SD, 2D only)	 <p><Condition> Presser foot: Buttonhole foot Buttonhole stitch adjuster : Center <SD> Pattern selection dial: "1" to "4" <2D> Pattern selection dial: "11" to "14" <Diagnosis> ◆When about 50 stitches have been stitched each at right and left sides of buttonhole, measure the difference of stitch width at right and left.</p>	Width must be the same at right and left.	[Adjustment] page.39

8.Improper lower thread winding length

<p>[Example of phenomenon]</p>  <p>Uneven lower thread Too much or too little winding</p>	<p>[Check item before adjustment]</p> <ul style="list-style-type: none"> ◆Is the upper thread threaded on the thread guide? ◆Is the upper thread threaded on the lower thread guide? ◆Is the lower thread threaded properly through the bobbin hole?
---	---

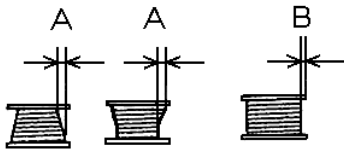
Step	Item	Diagnosing Method	Standard	Reference Page
1. Bobbin	Winding amount of lower thread	 <p><Condition> Thread: Cotton yarn # 60 Wind-up: When the wound thread contacts the bobbin stopper and the bobbin stops</p> <p><Diagnosis></p> <ul style="list-style-type: none"> ◆Set the bobbin on the bobbin winder shaft. ◆When the bobbin has returned to the original position (to left) after winding up the lower thread, measure the states of winding (A, B). A: Winding deviation B: Winding amount 	A = 1.5 mm or less B = 1.5 to 2.0 mm	[Adjustment] page.36

9.Improper upper threading

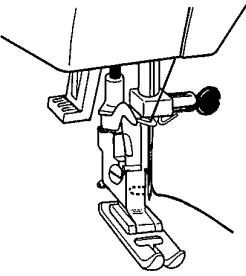
<p>[Example of phenomenon]</p> 	<p>[Check item before adjustment]</p> <ul style="list-style-type: none"> ◆Is the needle positioned at the top? ◆Is the thread threaded properly through the needle guide? ◆Is the upper thread threaded properly? ◆Is the needle installed correctly? ◆Is a needle # 11 to # 16 used? ◆Is the needle bent?
--	--

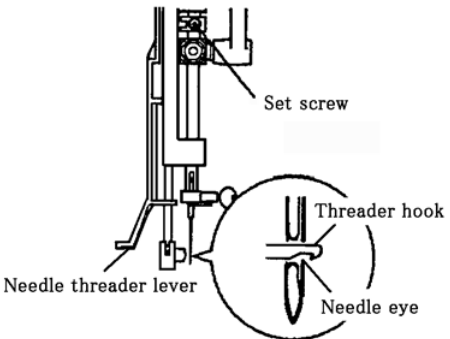
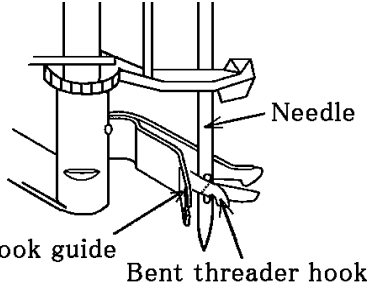
Step	Item	Diagnosing Method	Standard	Reference Page
1. Needle threader	Needle threader height	 <p><Condition> Needle: # 11 to # 16</p> <p><Diagnosis></p> <ul style="list-style-type: none"> ◆When the needle bar is brought to the upper dead point by turning the handwheel, check the movement of needle threader lever by pressing it down. 	Threader hook must pass through the needle hole without smoothly.	[Adjustment] page.38
	Bent threader hook	 <p><Diagnosis></p> <ul style="list-style-type: none"> ◆Check the shape of threader hook. 	Threader hook must not be bent.	[Adjustment] page.38

3.Adjustment of respective parts

1.Needle bar position

Needle bar height

[Condition]

Needle: # 14

[Diagnosis]

1. Remove the extension table, and open the shuttle cover.
2. When the needle bar is brought to the lower dead point by rotating the handwheel, measure the clearance (A) between the needle point and the shuttle hook center.(Fig. 1)

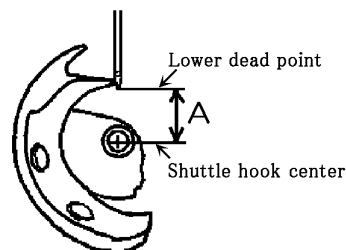

Fig.1

[Standard]

A = 11.2 ± 0.2 mm (Fig.1)

* Make adjustment if the diagnosis result fails to meet the standard.

[Adjustment]

1. Turn the handwheel, bring the needle bar to the lower dead point.
2. Loosen the set screw, adjust the height and direction of needle bar.(Fig. 2)
3. Tighten the set screw.(Fig. 2)

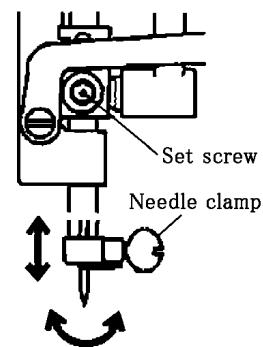

Fig.2

[Note]

- ◆After adjusting the height, confirm the orientation of needle bar as described in the next step.
- ◆When the needle threader is equipped, confirm that the thread passes through properly. (See:page.23)

* Repeat the adjustment till the standard is met.

Needle bar direction

[Diagnosis]

1. Remove the face cover.(See:page.45)
2. Check the needle clamp position.(Fig. 3)
3. When seeing from the top, measure the angle (A) in the figure.(Fig. 3)

[Standard]

Needle clamp position:

Just beside when seeing from the top (Fig. 3)
(Right side seeing from the front)

A = 0° to 1.5° (Fig.3)

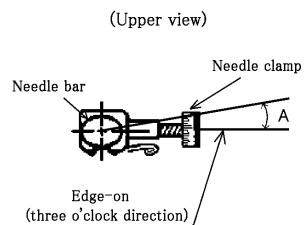

Fig.3

* Make adjustment if the diagnosis result fails to meet the standard.

[Adjustment]

1. See the needle bar height [Adjustment] above.

[Note]

- ◆ When the needle threader is equipped, confirm that the thread passes through properly. (See:page.23)

* Repeat the adjustment till the standard is met.

2. Timing between needle and hook

Amount of needle elevation

[Condition]

<SD>

Pattern selection dial: "5"

<2D>

Pattern selection dial: "3"

<3D>

Pattern selection dial: "4"

[Diagnosis]

1. Remove the extension table, and open the shuttle cover.
2. When the hook blade point is aligned with the needle center by rotating the handweel, measure the travel distance (A) of needle bar, regarding the lower dead point of needle bar as 0.(Fig. 1)

[Standard]

A = 1.85 ± 0.15 mm (Fig.1)

- * Make adjustment if the diagnosis result fails to meet the standard.

[Adjustment]

1. Remove external panels and others to allow sewing machine seen from the bottom. (See:page.45)
2. Loosen the screw at the right side of lower shaft, adjust the position of hook.(Fig. 2)
3. Tighten the screw.(Fig. 2)

- * Repeat the adjustment till the standard is met.

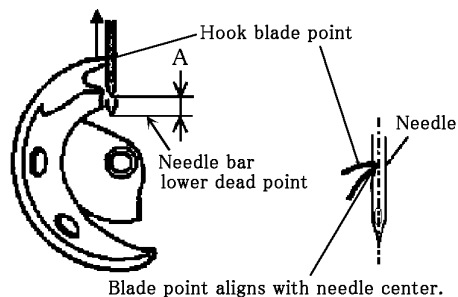

Fig.1

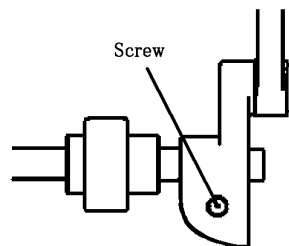

Fig.2

Clearance between needle and hook

[Condition]

<SD>

Pattern selection dial: "6"

<2D>

Pattern selection dial: "4"

<3D>

Pattern selection dial: "3"

Stitch width lever: "0"

[Diagnosis]

1. Turn the handweel beyond the lower dead point of needle bar. When the hook blade point has protruded by 0.1 to 0.2 mm from the side face of needle, measure the clearance (A) between the needle and the hook.(Fig. 3)

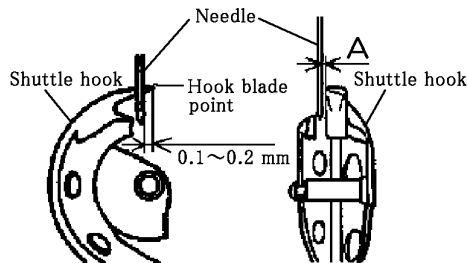

Fig.3

[Standard]

A = 0.03 to 0.08 mm (Fig. 3)

* Make adjustment if the diagnosis result fails to meet the standard.

[Adjustment]

1. Remove the face cover to see the adjusting section.(See:page.45)
2. Loosen the adjustment shaft nut at the upper part of needle and adjust by turning the adjustment shaft.(Fig. 4)
 - ♦Right turn increases the clearance.
 - ♦Left turn decreases the clearance.
3. Tighten the nut.(Fig. 4)

* Repeat the adjustment till the standard is met.

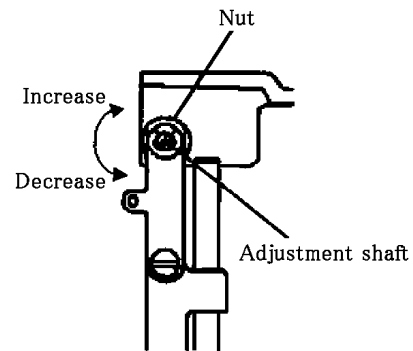

Fig.4

3. Clearance between needle and upper plate spring

[Condition]

<SD>

Pattern selection dial: "11"

<2D>

Pattern selection dial: "7"

<3D>

Pattern selection dial: "3"

Stitch width lever: "5"

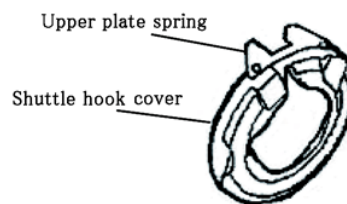

Fig.1

[Diagnosis]

1. When the needle bar is brought to the lower dead point at the right side by rotating the handwheel, measure the clearance (A, B) between the needle and the upper plate spring. (Fig. 2)

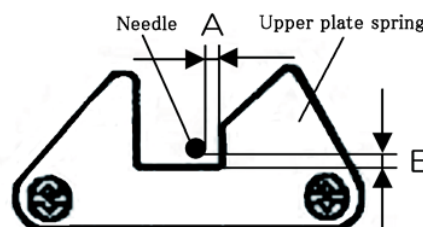

Fig.2

[Standard]

A = 0.5 to 1.2 mm

B = 0.5 to 1.0 mm (Fig. 2)

- * Make adjustment if the diagnosis result fails to meet the standard.

[Adjustment]

1. Remove the extension table, and open the shuttle cover.
2. Remove the shuttle hook cover.
3. Loosen the shuttle hook cover adjustment screw, adjust the position of upper plate spring. (Fig. 3)

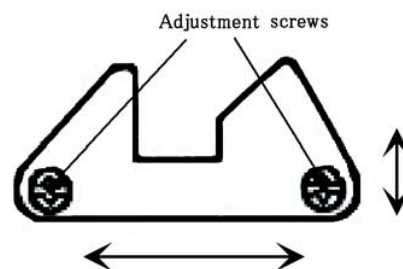

Fig.3

- * Repeat the adjustment till the standard is met.

4. Stitch width

(3D only)

[Condition]

Pattern selection dial: "4"

[Diagnosis]

1. Move the stitch width lever to left till the lever is stopped.
2. Check the state of stitch after sewing a fabric.
(Fig. 1)

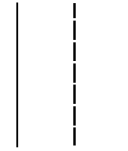

Fig.1

[Standard]

Stitches must be straight. (Fig. 1)

* If the stitches become zigzag as a result of diagnosis, adjust this.

[Adjustment]

1. Remove the external panels and others to see the adjusting section. (See:page.45)
2. Loosen the screw, move the stitch width lever to left till the lever is stopped.(Fig. 2)
3. Push the stitch width lever till it contacts stopper, then tighten the screw.(Fig. 2)

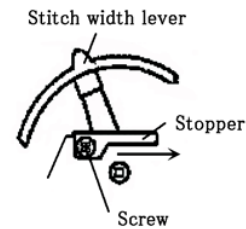

Fig.2

* Repeat the adjustment till the standard is met.

5. Needle location

Straight needle dropping points

[Condition]

<SD>

Pattern selection dial: "6"

<2D>

Pattern selection dial: "4"

<3D>

Pattern selection dial: "3"

Stitch width lever: "0"

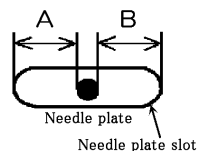

Fig.1

[Diagnosis]

1. Rotate the handwheel, bring down the needle lower than the surface of needle plate.
2. Measure the relative position (A, B) between the needle and the slot.(Fig. 1)

[Standard]

A = B (Fig. 1)

- * Make adjustment if the diagnosis result fails to meet the standard.

[Adjustment]

1. Remove the external panels and others to see the adjusting section. (See:page.45)
2. Turn the eccentric pin, adjust the needle location.(Fig. 2)
 - ♦Right turn moves the needle location to "Left".
 - ♦Left turn moves the needle location to "Right".

- * Repeat the adjustment till the standard is met.

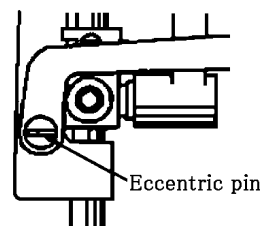

Fig.2

Zigzag needle dropping points

[Condition]

<SD>

Pattern selection dial: "11"

<2D>

Pattern selection dial: "7"

<3D>

Pattern selection dial: "3"

Stitch width lever: "5"

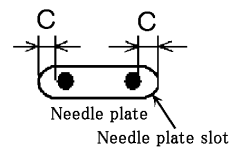

Fig.3

[Diagnosis]

1. Rotate the handwheel, bring down the needle lower than the surface of needle plate.
2. Measure the relative position (C) between the needle and the slot.(Fig. 3)

[Standard]

C = 0.7 ± 0.3 mm (Fig.3)

- * Make adjustment if the diagnosis result fails to meet the standard.

[Adjustment]

1. Remove the external panels and others to see the adjusting section. (See:page.45)
2. Turn the adjustment screw, adjust the needle location.(Fig. 4)

* Repeat the adjustment till the standard is met.

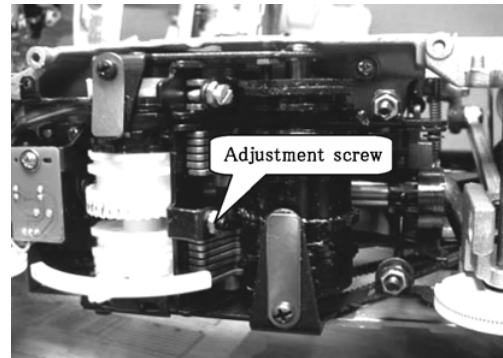

Fig.4

6. Needle sideways movement

[Condition]

<SD>

Pattern selection dial: "11"

<2D>

Pattern selection dial: "7"

<3D>

Pattern selection dial: "3"

Stitch width lever: "5"

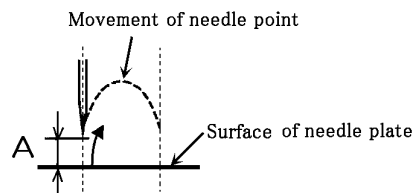

Fig.1

[Diagnosis]

1. When the needle travels from left to right, measure the distance (A) from the surface of needle plate to the needle point.(Fig. 1)

[Standard]

<SD, 2D>

A = 5 to 7 mm

<3D>

A = 3 to 5 mm (Fig. 1)

- * Make adjustment if the diagnosis result fails to meet the standard.

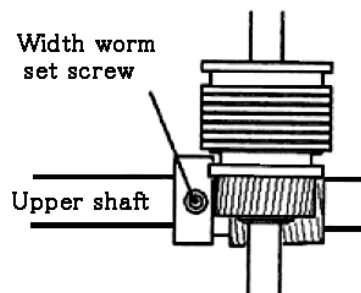

Fig.2

[Adjustment]

1. Remove the external panels and others to see the adjusting section. (See:page.45)
2. Loosen the upper shaft width worm set screw, adjust the phase of pattern cam.(Fig. 2)
3. Tighten the upper shaft width worm set screw.(Fig. 2)

[Note]

- ◆ Pay attention not to move the width worm in the axial direction.

- * Repeat the adjustment till the standard is met.

7.Thread tension

Upper thread tension

[Condition]

Upper thread tension dial: "5"
Thread: Cotton yarn # 60

[Diagnosis]

1. Pass the upper thread from the spool of thread to the thread guide. Pull the thread vertically and measure the tension (A) when the value has stabilized .
(Using a measuring instrument) (Fig. 1)

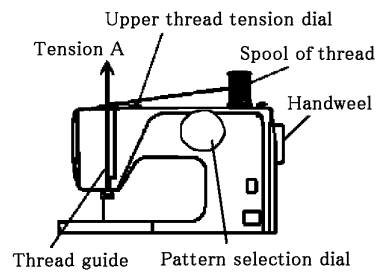

Fig.1

[Standard]

A = 0.85 to 1.15 N (Fig. 1)

- * Make adjustment if the diagnosis result fails to meet the standard.

[Adjustment]

1. Remove the external panels and others to see the adjusting section. (See:page.45)
2. Turn the upper thread tension dial, adjust the upper thread tension.(Fig. 2)
 - ♦Turn to deep side increases the tension.
 - ♦Turn to front side decreases the tension.

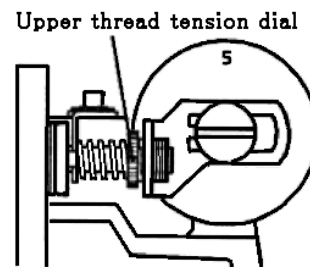

Fig.2

- * Repeat the adjustment till the standard is met.

Lower thread tension

[Condition]

Thread: Cotton yarn # 60

[Diagnosis]

1. After setting a bobbin in the bobbin case, pull out the lower thread through the lower thread guide. Measure the tension (A) when the value has stabilized.
(Using a measuring instrument) (Fig. 3)

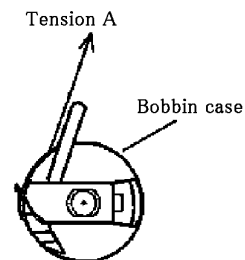

Fig.3

[Standard]

A = 0.3 to 0.4 N (Fig. 3)

- * Make adjustment if the diagnosis result fails to meet the standard.

[Adjustment]

1. Turn the bobbin case adjustment screw, adjust the lower thread tension.(Fig. 4)
 - ♦Right turn increases the tension.
 - ♦Left turn decreases the tension.

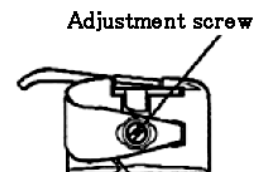

Fig.4

- * Repeat the adjustment till the standard is met.

8.Feed dog position

Feed dog height

[Diagnosis]

1. Bring up the presser foot and attach the needle on the needle bar.
(In order to clarify the needle bar position)
2. When the feed dog is brought to the highest position (= upper dead point of needle bar) by rotating the handwheel, measure the distance (A) between the surface of needle plate and the upper limit of feed dog.(Fig. 1)

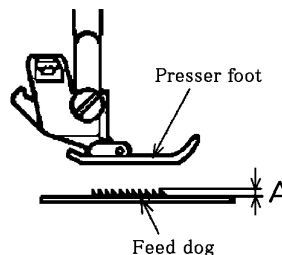

Fig.1

[Standard]

A = 1.15 ± 0.1 mm (Fig.1)

- * Make adjustment if the diagnosis result fails to meet the standard.

[Adjustment]

1. Remove the external panels and others to see the adjusting section. (See:page.45)
2. Turn the adjustment screw at the left side of lower shaft, adjust the feed dog height.(Fig. 2)
 - ♦Right turn raises the feed dog.
 - ♦Left turn lowers the feed dog.

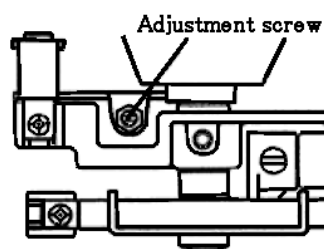

Fig.2

- * Repeat the adjustment till the standard is met.

Fore and aft position of feed dog

[Condition]

<SD>

Pattern selection dial: "8"

<2D, 3D>

Stitch length dial: "5"

[Diagnosis]

1. Remove the presser foot.
2. When the feed dog is brought to the highest position (= upper dead point of needle bar) by rotating the handwheel, measure the fore and aft position (A) of feed dog.(Fig. 3)

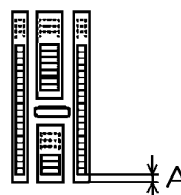

Fig.3

[Standard]

A = 1.0 ± 0.5 mm (Fig.3)

- * Make adjustment if the diagnosis result fails to meet the standard.

[Adjustment]

1. Remove the external panels and others to see the adjusting section. (See:page.45)
2. Loosen the feed rock arm set screw at the right side of lower shaft, adjust the fore and aft position of feed dog.(Fig. 4)

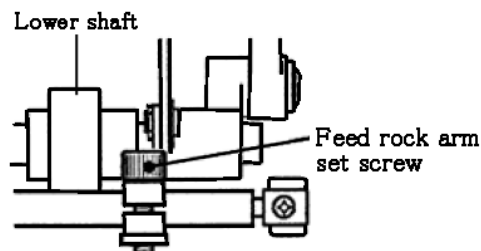

Fig.4

- * Repeat the adjustment till the standard is met.

Crosswise position of feed dog

[Diagnosis]

1. Remove the presser foot.
2. When the feed dog is brought to the highest position (= upper dead point of needle bar) by rotating the handwheel, measure the sideways position (A, B) of feed dog.(Fig. 5)

[Standard]

A = B (Fig. 5)

- * Make adjustment if the diagnosis result fails to meet the standard.

[Adjustment]

1. Remove the face cover and the rear cover to see the adjusting section. (See:page.45)
2. Loosen the feed bar set screws, position the feed dog at the center between right and left.(Fig. 6)

- * Repeat the adjustment till the standard is met.

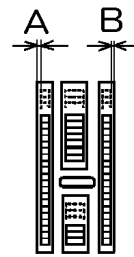

Fig.5

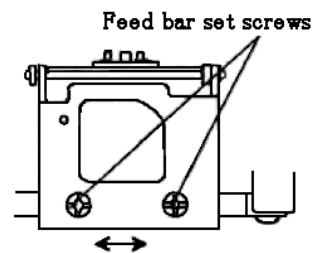

Fig.6

9. Lower thread winding length

[Condition]

Thread: Cotton yarn # 60

Wind-up: When the wound thread contacts the bobbin stopper and the bobbin stops

[Diagnosis]

1. Set the bobbin on the bobbin winder shaft.
2. When the bobbin has returned to the original position (to left) after winding up the lower thread, measure the states of winding (A, B). (Fig. 1)

A: Winding deviation

B: Winding amount

[Standard]

A = 1.5 mm or less (One-sided winding)

B = 1.5 to 2.0 mm (Winding amount) (Fig. 1)

* Make adjustment if the diagnosis result fails to meet the standard.

[Adjustment]

1. Adjustment of one-sided winding
 - (1) Loosen the thread guide plate set screw, adjust the position of the thread guide plate up and down. (Fig. 2)
 - Higher bracket position increases the winding amount of higher side of bobbin.
 - Lower bracket position increases the winding amount of lower side of bobbin.
 - (2) Tighten the thread guide plate set screw. (Fig. 2)

* Repeat the adjustment till the standard is met.

2. Adjustment of winding amount
 - (1) Loosen the bobbin stopper set screw, turn the bobbin stopper to adjust. (Fig. 2)
 - Right turn decreases the winding amount.
 - Left turn increases the winding amount.
 - (2) Tighten the bobbin stopper set screw. (Fig. 2)

* Repeat the adjustment till the standard is met.

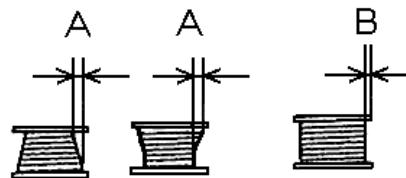

Fig.1

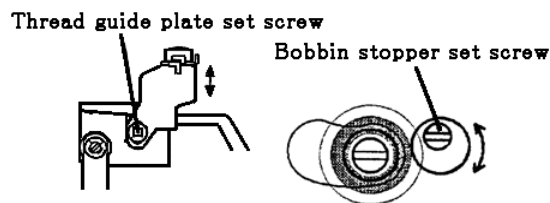

Fig.2

10.Presser foot height

Presser foot height

[Diagnosis]

1. Set the presser foot.
2. Lift the presser foot.
3. Measure the clearance (A) between the presser foot and the surface of needle plate. (Fig. 1)

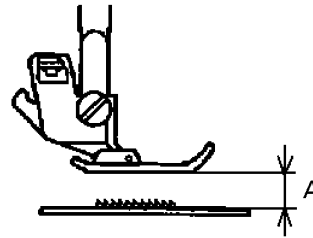

Fig.1

[Standard]

A = 5 to 6 mm (Fig. 1)

* Make adjustment if the diagnosis result fails to meet the standard.

[Adjustment]

1. Remove the face cover to see the adjusting section. (See:page.45)
2. Loosen the presser bar bracket set screw, adjust the presser foot height.(Fig. 2)
3. Tighten the presser bar bracket set screw. (Fig. 2)

[Note]

◆ Confirm that the presser foot is not tilted to right or left.

* Repeat the adjustment till the standard is met.

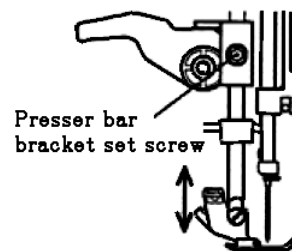

Fig.2

11. Needle threader

Needle threader height

[Condition]

Needle: # 11 to # 16

[Diagnosis]

1. When the needle bar is brought to the upper dead point by turning the handwheel, check the movement of needle threader lever by pressing it down. (Fig. 1)

[Standard]

Threader hook must pass through the needle hole without smoothly. (Fig. 1)

- * Make adjustment if the diagnosis result fails to meet the standard.

[Adjustment]

1. Remove the face cover to see the adjusting section. (See:page.45)
2. Loosen the threader arm set screw, adjust the height of threader arm. (Fig. 1)

- * Repeat the adjustment till the standard is met.

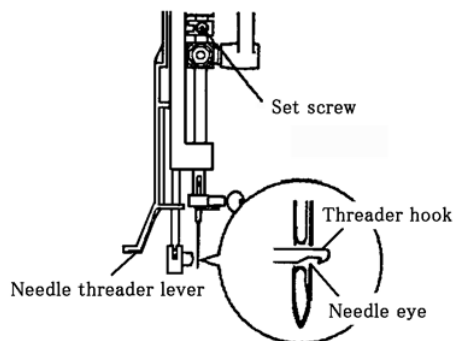

Fig.1

Bent threader hook

[Diagnosis]

1. Check the shape of threader hook. (Fig. 2)

[Standard]

Threader hook should not be bent. (Fig. 2)

- * Make adjustment if the diagnosis result fails to meet the standard.

[Adjustment]

1. Straighten the threader hook using a screwdriver or the like, so that hook can pass through the needle hole smoothly.
2. If the bent cannot be corrected properly, replace the threader hook.

- * Repeat the adjustment till the standard is met.

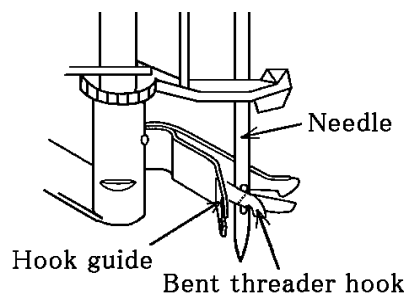

Fig.2

12.Buttonhole sewing

Difference of stitches at right and left

[Condition]

Presser foot: Buttonhole foot
 Buttonhole stitch adjuster: Center
 <SD>
 Pattern selection dial: "1" to "4"
 <2D>
 Pattern selection dial: "11" to "14"
 <3D>
 Pattern selection dial: "8"

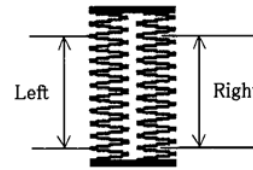

Fig.1

[Diagnosis]

1. When about 50 stitches have been stitched each at right and left sides of buttonhole, measure the difference of stitches at right and left.(Fig. 1)

[Standard]

Left: 35 stitches, standard
 Right: 30 to 41 stitches
 Feeding amounts are nearly the same at right and left (Fig. 1)

- * Make adjustment if the diagnosis result fails to meet the standard.

[Adjustment]

1. Remove the external panels and others to see the adjusting section. (See:page.45)
2. Turn the adjustment screw, eliminate the difference of stitch numbers at right and left. (SD: Fig. 2, 2D/3D: Fig. 3)
 - ◆When the stitches at left is coarser than the right, turn the screw to right.
 - ◆When the stitches at right is coarser than the left, turn the screw to left.

- * Repeat the adjustment till the standard is met.

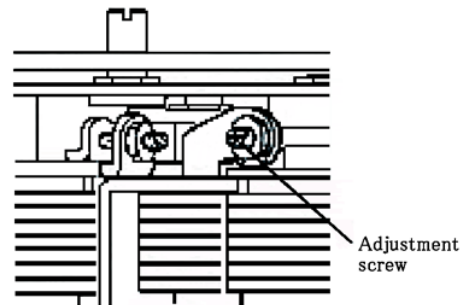

Fig.2(SD)

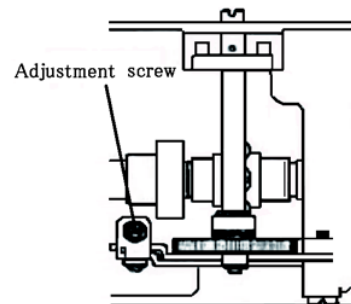

Fig.3(2D,3D)

Differential width at right and left (SD, 2D only)

[Condition]

Presser foot: Buttonhole foot
 Buttonhole stitch adjuster: Center
 <SD>
 Pattern selection dial: "1" to "4"
 <2D>
 Pattern selection dial: "11" to "14"

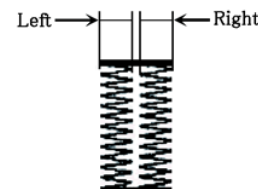

Fig.4

[Diagnosis]

1. When about 50 stitches have been stitched each at right and left sides of buttonhole, measure the difference of stitch width at right and left.(Fig. 4)

[Standard]

Width must be the same at right and left. (Fig. 4)

* Make adjustment if the diagnosis result fails to meet the standard.

[Adjustment]

1. Remove the external panels and others to see the adjusting section. (See:page.45)
2. Turn the adjustment screw, eliminate the difference of stitch width at right and left. (Fig. 5)

- ◆When the width at left is narrower than right, turn the screw to right.
- ◆When the width at right is narrower than left, turn the screw to left.

* Repeat the adjustment till the standard is met.

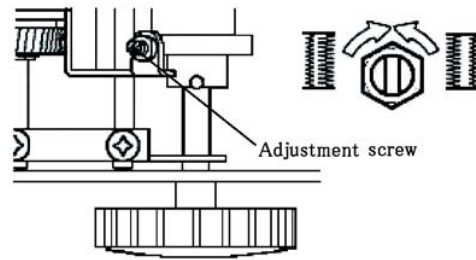

Fig.5

13. Feeding amount

(Exclude SDU type)

Pattern stitch feeding amount

[Condition]

<SD, 2D>

Pattern selection dial: "16"

<3D>

Pattern selection dial: "17"

Stitch width lever: "5"

[Diagnosis]

1. Measure the maximum feeding amount (A) during pattern stitching. (Fig. 1)

[Standard]

$A = 2.8 \pm 0.3$ mm, and

Pattern shall not be opened or overlapped. (Fig. 1)

- * Make adjustment if the diagnosis result fails to meet the standard.

[Adjustment]

1. Remove the external panels and others to see the adjusting section. (See: page.45)
2. Turn the adjustment screw, adjust the pattern feeding amount. (SD: Fig. 2, 2D/3D: Fig. 3)
 - Right turn increases the feeding amount.
 - Left turn decreases the feeding amount.

- * Repeat the adjustment till the standard is met.



Fig.1

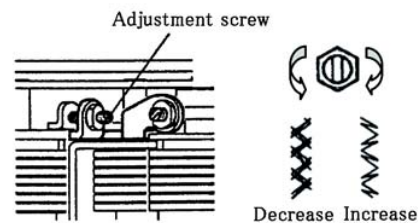

Fig.2(SD,2D)

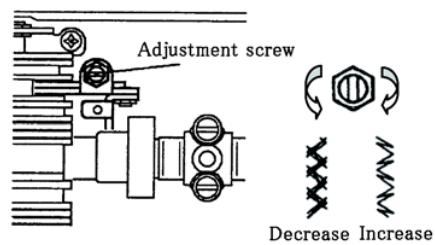

Fig.3(3D)

14. Clearance between shuttle driver and shuttle hook

[Diagnosis]

1. Remove the extension table, and open the shuttle cover.
2. Remove the bobbin case from the hook.
3. When the shuttle driver is turned to left by rotating the handweel, measure the clearance (A) between the shuttle driver and the shuttle hook. (Fig. 1)

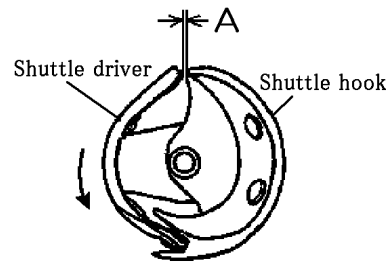

Fig.1

[Standard]

A = 0.3 to 0.6 mm (Fig. 1)

- * Make adjustment if the diagnosis result fails to meet the standard.

[Adjustment]

1. Bend or extending the tip of driver spring, adjust the clearance between the shuttle driver and the shuttle hook. (Fig. 2)

[Note]

- ◆ If it cannot be adjusted, replace the driver spring.

- * Repeat the adjustment till the standard is met.

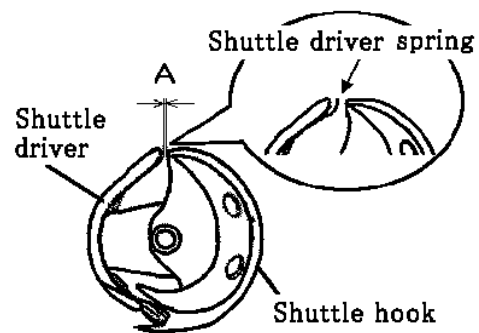

Fig.2

15. Belt tension

Motor belt tension

[Diagnosis]

1. Remove the external panels and others.
(See:page.45)
2. When pressing the center of motor belt with a force of 3N, measure the depth of flexure (A) on the belt.(Fig. 1)

[Standard]

A = 7.0 to 9.0 mm (Fig. 1)

- * Make adjustment if the diagnosis result fails to meet the standard.

[Adjustment]

1. Loosen a pair of adjustment screws and adjust the motor position.(Fig. 2)

- * Repeat the adjustment till the standard is met.

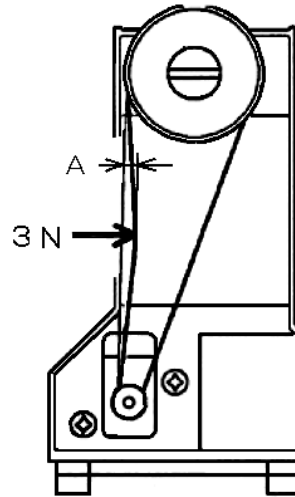

Fig.1

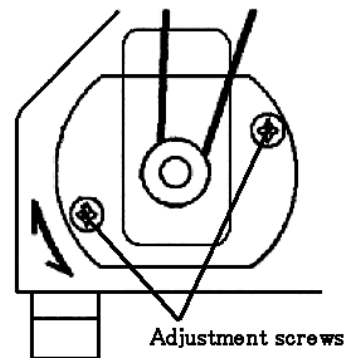

Fig.2

Pattern selecting cam driving belt tension (Pattern selection dial: Right side face model only)

[Diagnosis]

1. Remove the external panels and others.
(See:page.45)
2. When pressing the center of pattern selecting cam driving belt with a force of 3N, measure the depth (A) of flexure on the belt.(Fig. 3)

[Standard]

A = 3.0 to 5.0 mm (Fig. 3)

- * Make adjustment if the diagnosis result fails to meet the standard.

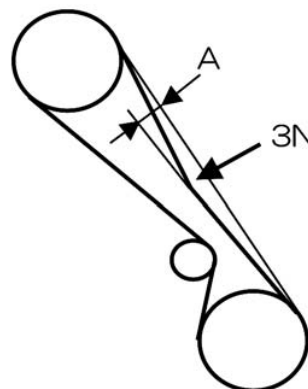

Fig.3

Adjustment of respective parts

[Adjustment]

1. Loosen the idler pulley adjustment screw, adjust the idler pulley position.(Fig. 4)

* Repeat the adjustment till the standard is met.

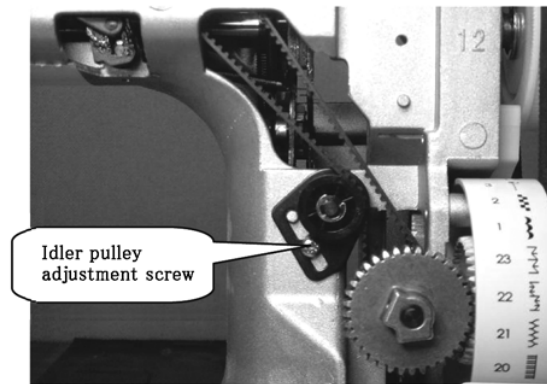

Fig.4

4. Removal and reassembling of main components

1. External panels, etc.

[Note] Use a magnetic screwdriver in order to prevent screws from dropping in the sewing machine.

1. Remove the face cover

- (1) Remove the screw (A).
- (2) Remove the face cover. (Bring up to left top.)

2. Remove the rear cover

- (1) Slide the extension table to left and remove.
- (2) Remove the pattern selection dial.
- (3) Remove 3 pieces of rubber foot and a pair of screws (C).
- (4) Remove a pair of screws (E) and a piece of screw (D) at the rear part of main body.
- (5) Lift the presser foot lever, tilt the main body forward.
- (6) Pull out the spool pin from the main body.
- (7) While pushing downward the section (F), remove the rear cover.

3. Remove the front cover

- (1) Remove a piece of screw (G).
- (2) Raise the main body.
- (3) Loosen a piece of screw (H). (Front corner set screw)
- (4) Remove a piece of screw (J).
- (5) Remove a pair of screws (K). (Thread guide plate set screw)
- (6) Lower the presser foot lever and tilt the main body backward.
- (7) Disengage the stopper at the section (M). While expanding the lower part (bottom) of panel and the right side face outward, bring up and remove the front cover.

[Caution] Pay attention not to cut fingers with the cover edges.

* Install the panel in the reverse order of removal.

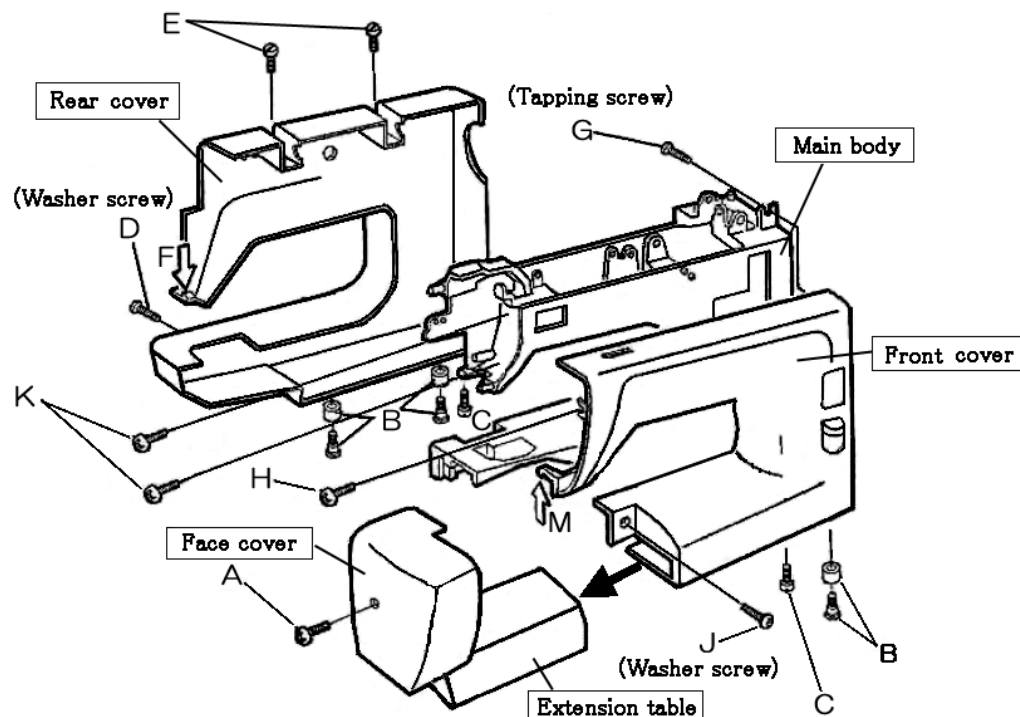

AISIN SEIKI Co.,Ltd.

Home Sewing & TSS Dept.

Home Sewing Group

2-1 Asahi-machi, Kariya City, Aichi 448-8650 Japan

Phone: +81-566-24-8694 Fax: +81-566-24-8895

<http://www.aisin.com> E-mail:fashion@cld.aisin.co.jp

RS2000 S/M-0510
Printed in Japan